

# Watson-Marlow on process water and wastewater treatment in the food industry

## Meeting environmental and sustainability responsibilities

---



# CONTENTS

---

Executive summary	3
Water treatment: a critical process	5
Health, safety and compliance	6
Dosing best practice	8
Case study: Brewery pump replacement	9
Operation and maintenance	10
Assessing lifecycle cost	12
Case study: Dosing for sugar processing	13
Locking in sustainability	14
About Watson-Marlow Fluid Technology Solutions	15

# EXECUTIVE SUMMARY

In the competitive food and beverage market, standards for health and safety and environmental compliance are of critical importance.

There are significant reputational and financial consequences for putting products or the environment at risk through poorly managed systems and processes.

The food and beverage industry uses vast volumes of water, and treatment of water and wastewater is essential to every production plant. It is a complex and costly process with every site required to meet specific environmental discharge regulations.

This report looks at the critical process of water treatment in food and beverage production and explores how best practice in chemical dosing is a key factor in mitigating risks from breaches in health and safety and compliance.

With water an increasingly scarce resource, sustainability is also an important consideration. The report also looks in more depth at sustainability issues and includes two industry examples on how companies have optimized operating processes and reduced their environmental footprint.







# WATER TREATMENT: A CRITICAL PROCESS

Before it reaches the manufacturer, the agricultural component of the food value chain accounts for roughly 70 percent of global freshwater withdrawals (FAO, 2016).

Once out of the farm gate, food and drink is the industrial sector with the highest water consumption, representing 56 percent of total industrial water use and approximately 190 million cubic metres of water annually in the UK alone (Environment Agency, 2013), a breakdown reflected across the world.

Appropriate treatment of process water and wastewater is fundamental to the safe and efficient operation of every food and beverage production plant. These are complex and costly processes, with each site potentially treating differing volumes of water, to varying standards, for a multitude of applications and to meet specific environmental discharge regulations.

Process water, used for food washing and preparation, pasteurisation, cleaning of equipment, steaming and sterilisation or as an additive or stabiliser accounts for the largest water use in the food sector, some 31 percent.

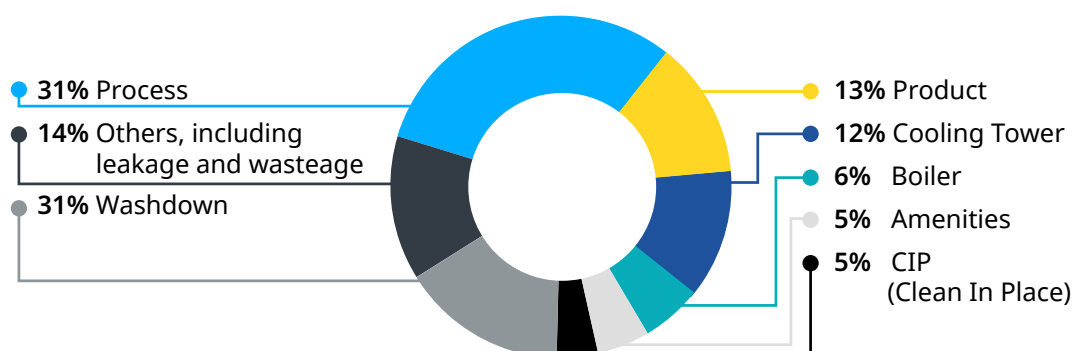

*Water use breakdown in a typical food manufacturing sector.*

*Source: Ellis et al.*

At the other end of the production line, wastewater must undergo high levels of treatment prior to discharge or reuse. Companies that opt to treat wastewater onsite, rather than through a trade effluent service, are bound to meet ever-tightening environmental standards before emission to watercourses.

Variability is a factor in food and beverage production that can present significant challenges to wastewater treatment systems. That includes seasonal changes, production increases or decreases and modifications to products and production lines - all of which can cause sudden changes to the volume or character of a waste stream.

It is essential that fluctuating waste stream volumes or pollutant concentrations can be accommodated by a safe, flexible and intuitive wastewater treatment system.

# HEALTH, SAFETY AND COMPLIANCE

In a competitive marketplace like food and beverage production, standards for health and safety and environmental compliance are critical. The industry is particularly exposed and the consequences of putting customers, staff, products or the environment at risk through poorly managed systems and processes cannot be countenanced.

The sensitivity of brand image for food and beverage companies and the wider supply chain, including retailers, means health and safety and pollution events can also be highly damaging to customer relationships.

Companies have a strict obligation to store water treatment chemicals safely and ensure risk to staff is given utmost consideration. Accidents can result in serious injury and lead to criminal proceedings and plant closures.

Legally binding environmental regulations, rooted in legislation like the European Water Framework Directive, the US Clean Water Act and the Australian National Water Initiative are in place to protect rivers, lakes, estuaries, coastal waters and groundwater from pollution. They stipulate that treated effluent must meet high quality standards before being released into the environment. Food and beverage companies in breach of water quality requirements risk prosecutions and large fines and even having their discharge permits revoked.

Observing best practice in chemical dosing is a key factor in mitigating risks from breaches in health and safety and compliance. It is necessary to maintain system parameters, optimize water quality and keep microbiological contaminants at bay. It is also key to minimizing the quantities of chemicals requiring handling, storage and administration.



# POLLUTION — IS IT WORTH THE RISK?

**UK 2020** Environment Agency, regulator for England and Wales, confirms that 52 companies with permits to discharge effluent from food will be investigated for possible pollution of watercourses.

---

**Malaysia 2020** Global food and beverage company fined RM90,000 (£16,000; US\$22,000) on two counts of releasing industrial effluent exceeding biochemical and chemical oxygen demand limit into inland waters.

---

**US 2020** Food producer in Nebraska pays US\$827,500 (£607,500) penalty and agrees to US\$2 million (£1,47 million) plant upgrade for releasing polluted water from egg processing plant to city treatment plant.

---

**UK 2020** Scottish brewery fined £10,000 (US\$13,600) for discharging caustic waste into a sewer, causing sewage works to overflow, leading to water contamination warnings.

---

**US 2020** A 367 litre (97-gallon) wine spill at a Californian facility overwhelmed drainage and impacted on a local river, violating federal and state clean water laws and potentially resulting in fines.

---

**France 2019** Large dairy company issued with €100,000 (US\$120,000; £88,000) fine for river pollution at cheese production site and €250,000 (US\$300,000; £220,000) fine for the same offense at a dairy operation run by a subsidiary.

---

**UK 2020** Food processor fined £50,000 (US\$68,000) for leaking untreated wastewater from chicken plant into a stream.

# DOSING BEST PRACTICE

The wide range of critical onsite treatment requirements across food and beverage sites need to be reliable, efficient, accurate and safe. Companies are also under pressure to keep costs to a minimum. In this context, accurate and reliable chemical dosing that ensures flows meet precise parameters is essential.

Chemicals are used for a range of applications including pH control, chlorination of feedwater, cleaning process equipment; foam control and adding flocculants and coagulants. Systems with a high level of automation help ensure accurate and repeatable levels of dosing that optimize chemical usage.

Dosing pumps operating in food and beverage applications require high levels of resolution, accuracy and control. This is to ensure that the correct amount of fluid is delivered, even in varying process conditions, removing any risk of under-dosing or over-dosing.

Peristaltic pumps, such as Watson-Marlow's Qdos peristaltic chemical metering pump, provide highly accurate dosing by enabling precise, incremental adjustments. They can handle applications requiring dosing at 0.1ml/min, right up to 2,000ml/min. By only using what is needed, chemical quantities and costs are reduced.

The health and safety profile of this vital equipment is an important consideration for any plant manager. Qdos pumps feature leak detectors which stop automatically and alert operators in the event of a pump-head failing or a hose leaking.

The units are self-contained and once the valves are shut off, the pumphead can be quickly removed and replaced without spillage. This minimizes the possibility of operators coming into contact with chemicals and prevents chemical spills into the environment. By comparison, failure of a traditional diaphragm dosing pump means the unit needs to be taken apart, risking chemical spillage and exposing staff to potential contact.





# CASE STUDY:

## BREWERY PUMP REPLACEMENT

An early-stage trial of the Qdos ReNu PU pump from Watson-Marlow Fluid Technology Solutions has proven its effectiveness at a large brewery in the UK. Environmental solutions provider SUEZ is contracted to operate and maintain the site's effluent treatment plant, working closely with the customer to identify and optimize the operating processes and reduce the brewery's environmental footprint.

SUEZ is using the Qdos ReNu PU for dosing polymer as part of the wastewater treatment process. The peristaltic pumps have replaced diaphragm metering pumps that were frequently becoming clogged with polymer the trial proved to be a complete success, with no issues experienced over an extended period of time.



*Watson-Marlow Qdos20 Universal+ with ReNu PU pumphead*

# OPERATION AND MAINTENANCE

It is essential that all machinery in the food and beverage industry is properly maintained and cleaned and that personnel are appropriately trained and follow procedures in full. The hazard analysis and critical control points system is the internationally recognized food-safety management tool that helps businesses identify, evaluate and control the hazards in their premises that pose a significant risk to food hygiene and safety.

Water and wastewater treatment must be maintained to a high standard; and the most efficient plants opt for a combination of preventative, reactive, proactive and predictive approaches. Operators must undertake to carry out corrective actions and establish procedures to ensure processes are operating effectively.

Equipment that is easy-to-install, operate and maintain will help minimize the procedural load and the risk of human error. This is especially important in a hazard-critical area like chemical dosing.

Low cost of ownership and accurate dosing are factors to consider in pump selection.

Peristaltic pumps meet a range of requirements including value for money, low cost of ownership, reliability and ease of maintenance. Qdos pumps require virtually no ancillary equipment and the patented pumphead can be replaced quickly and easily without tools for fast and safe maintenance.

# ADVANTAGES OF PERISTALTIC PUMPS

- Easy to install and maintain
- No risk of contamination or chemical spillage
- No specialist training required
- Remote management and monitoring
- Requires small site footprint

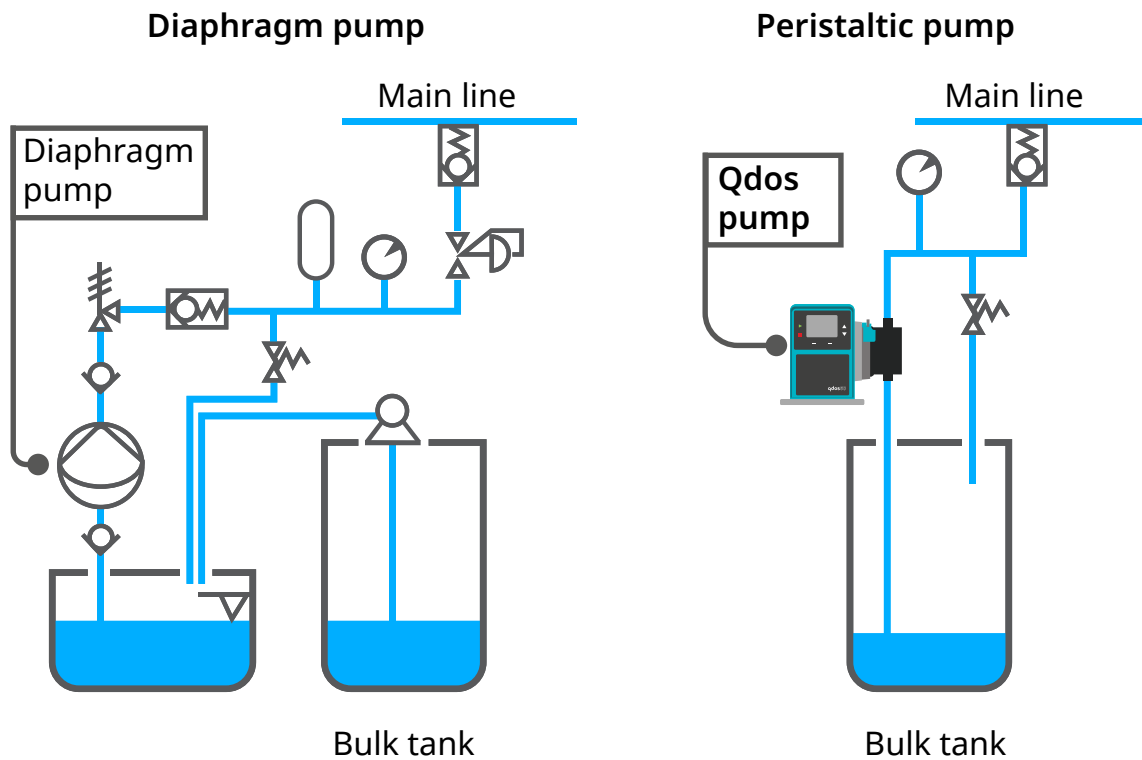

Simplicity of a chemical metering installation using a peristaltic pump compared to that required for a traditional diaphragm pump.



# ASSESSING LIFECYCLE COST

A number of variables impact the amount of energy consumed by a pump system, including specification, configuration and installation as well as how the system is operated and maintained. These factors are interdependent and must remain carefully matched and managed throughout the lifecycle of the pumping system.

Where projects are undertaken within limited capital budgets, priority may be given to upfront costs, with little consideration of ongoing expenditure. Lifecycle cost (LCC) analysis can give companies deeper understanding of the elements that make up the total cost of a system throughout its lifespan from purchase to decommissioning, including installation, operations and downtime.

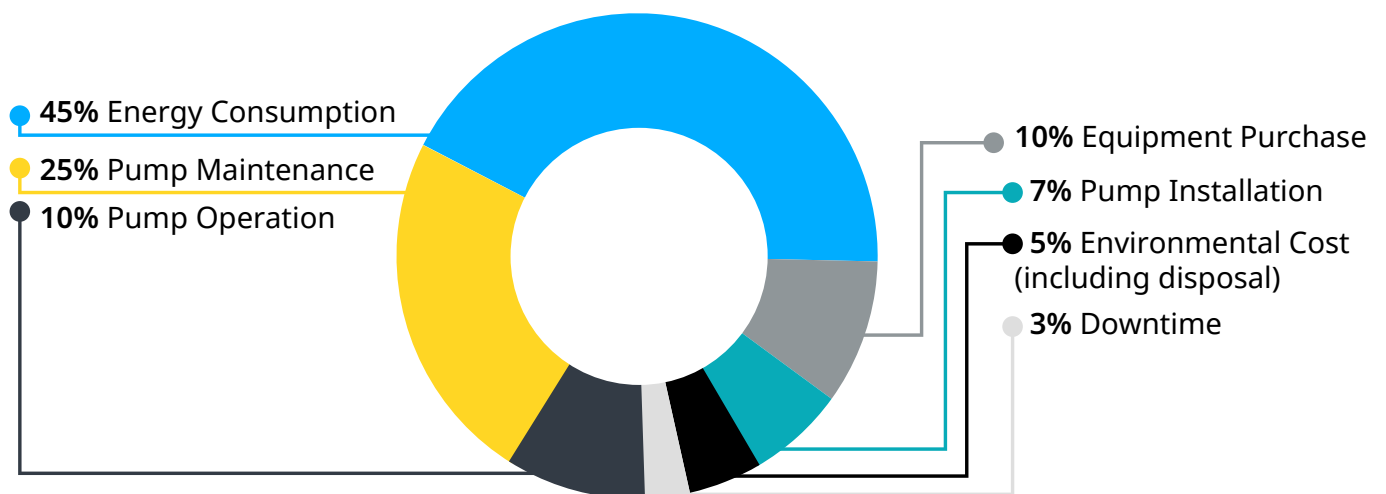

*Typical lifecycle cost profile of pump ownership.*

*Source: World Pumps, 2017.*

Another opportunity for significant cost-savings from systems' efficiency is in chemical consumption. Not only do pumps that dose more accurately reduce total chemical use, the health and safety risk from storing and processing chemicals is also reduced.

Peristaltic pumps, such as the Qdos pump, are capable of accurate and consistent chemical metering. This leads to efficient use of treatment chemicals and, because the fluid is fully contained within the pumphead, maintenance is safe, simple and quick, leading to a low total LCC.

## CASE STUDY:

# MAINTENANCE DOWNTIME CUT FROM 1.5 HOURS TO JUST FIVE MINUTES

An important stage of wastewater purification at Selters, Germany, is the elimination of phosphates with the addition of precipitants, including ferric chloride.

Ferric chloride is both chemically aggressive and abrasive and attacked the diaphragms of the pumps previously used at the sites' metering station. Technicians were replacing pump diaphragms every three to four months, and each one took at least one hour to change, plus clean up time for leaked chemical.

Qdos pumps were installed in the precipitant metering station and immediately reduced maintenance time to five minutes.



*Watson-Marlow Qdos30 Universal with ReNu pumphead*

# LOCKING IN SUSTAINABILITY

Water is a finite and increasingly scarce resource that needs to be sustained for future generations. It is also essential, in high volumes, to keep the food and beverage industry operating.

A report from the Environment Agency has shown that a reduction in water demand in food manufacturing is most likely to be made through efficiency gains within processes — along with effluent reuse, which accounted for around 22% of potential water savings in the sector (EA, 2013).

Globally, manufacturers are increasingly looking to reduce their exposure to risk from their water requirements through conservation, reuse and sustainability measures and some are undertaking localized whole-site reviews. The advantages are not only in reducing water footprint, but also in substantially reducing the cost of water supply, wastewater treatment, chemicals and even the energy bills arising from pumping, heating and cooling water.

As with any sustainability activity, changing company culture is an ongoing process and requires leadership and goal-setting across the business. It is a particularly important consideration in a sector like food and beverage where onsite management of water may impact directly on the local community and the end-customer is increasingly proactive around environmental concerns.

By adopting best-practice for process water and wastewater treatment and plant cleaning, and by identifying opportunities for water efficiency at every stage of the process, producers can move towards more sustainable practice.

Whatever the process and application — wastewater, clean water or recycled water — the dosing requirements remains the same. Production plants need robust and accurate systems with repeatable levels of dosing that mitigate the risk of permit breaches through underdosing or overdosing or system failure.

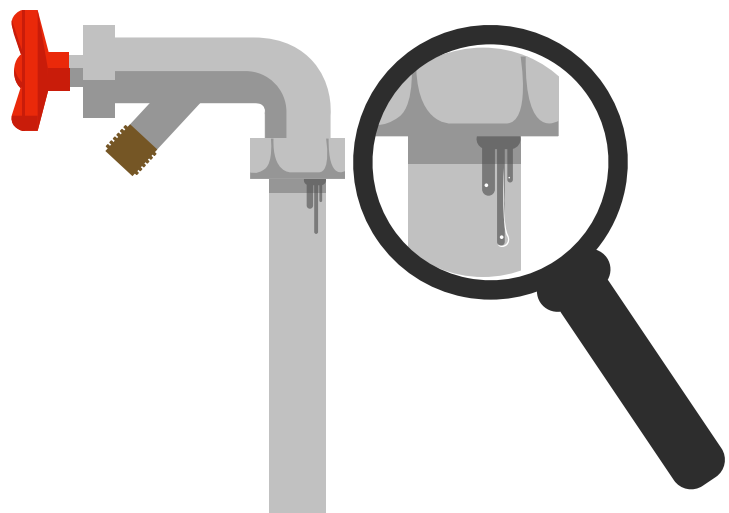



# ABOUT WATSON-MARLOW FLUID TECHNOLOGY SOLUTIONS



Watson-Marlow Fluid Technology Solutions is an award-winning, global leader in fluid management technology and for over 60 years has engineered components and systems for customers in the process industries and lifescience markets.

The company is part of Spirax-Sarco Engineering plc, a FTSE 100 company.

Learn more at [www.wmfts.com](http://www.wmfts.com) or [@WMFTS\\_news](https://twitter.com/WMFTS_news)